

Kit

## Double Bead Box Kit 24C528

3A0004D  
EN

*- For professional application of traffic marking reflective beads -*



### IMPORTANT SAFETY INSTRUCTIONS

Read all warnings and instructions in  
ThermoLazer Operation manual.

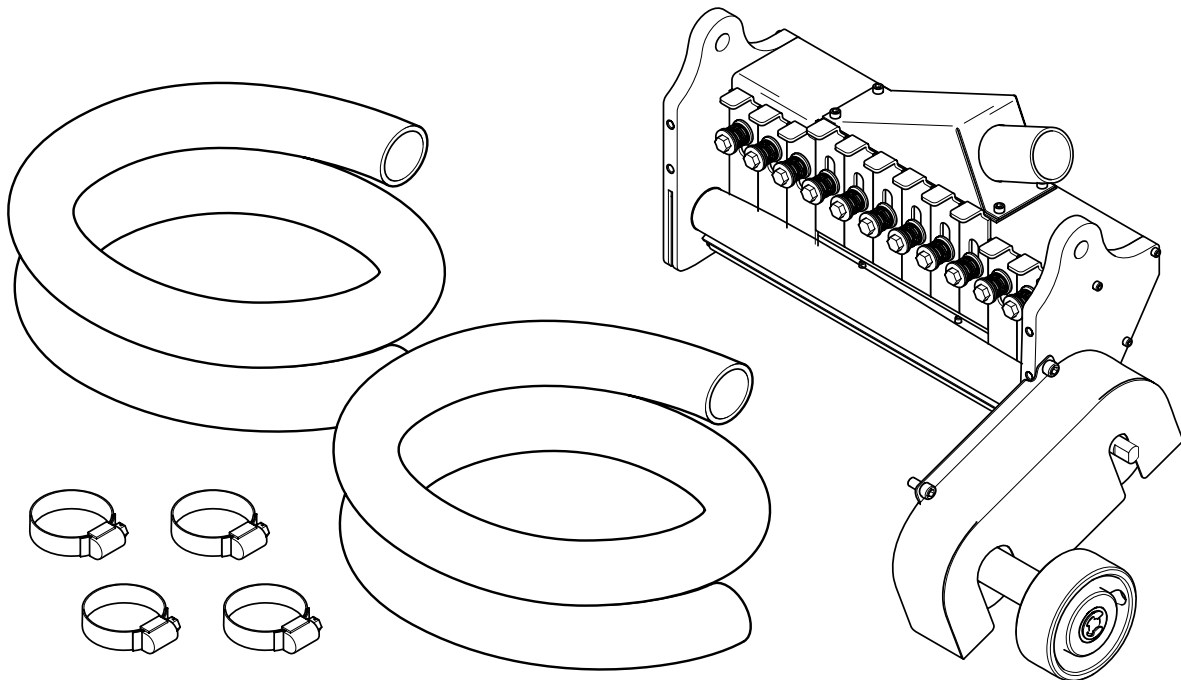

ti14581b

# Installation

1. Loosen screw on hose clamp and remove bead hose from dispenser.

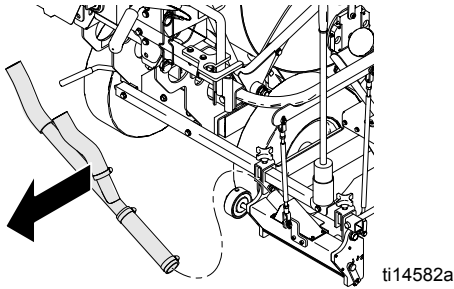

2. Loosen screw and remove bead dispenser engagement wheel.

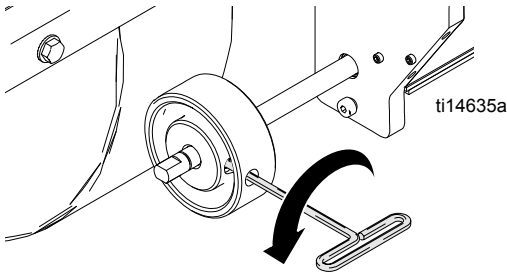

3. Install two angular inserts on bead dispenser and tighten screws.

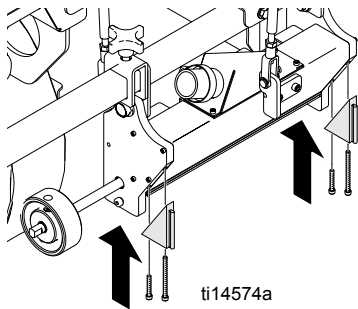

4. Slide double bead box down through slots on angular brackets and lock into place.

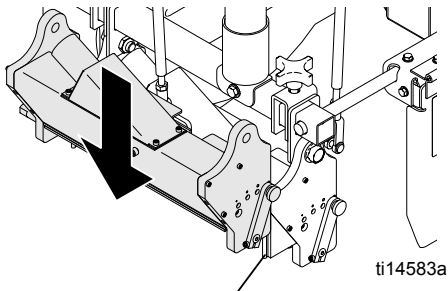

5. Slide single pulley over long axle.

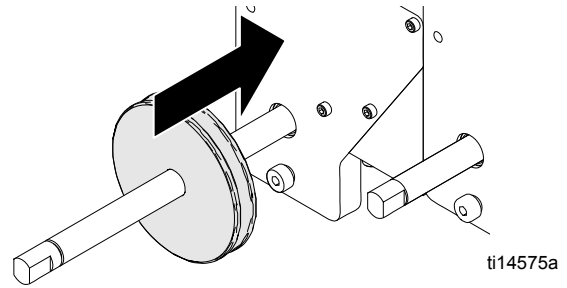

6. Slide bead dispenser engagement wheel pulley onto long axle.

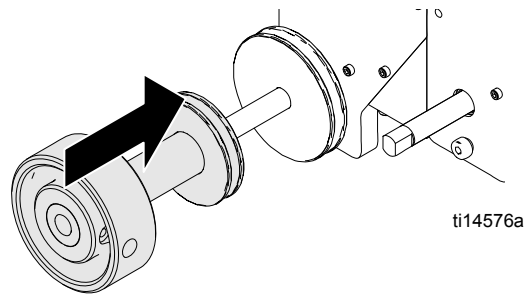

7. Secure pulley and wheel into place with clamp (engagement wheel pulley will still be able to rotate freely).

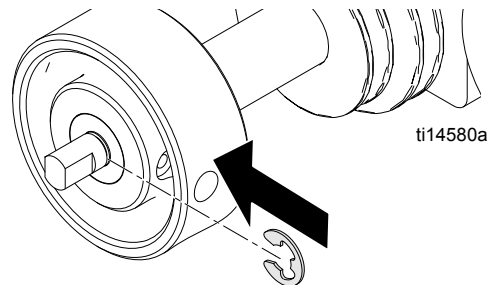

8. Slide pulley onto short axle.

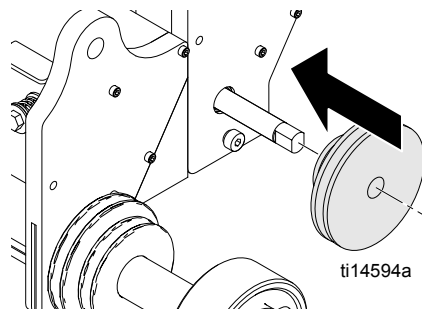

9. Install belts onto pulleys.

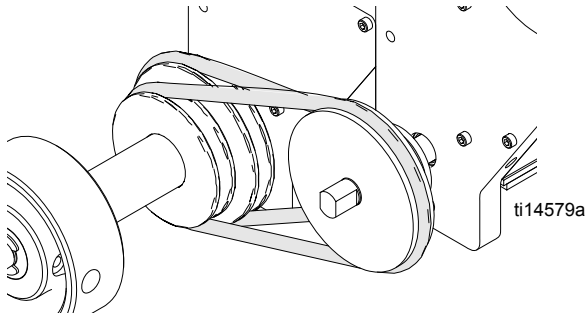

11. Attach pulley guard and tighten two screws.

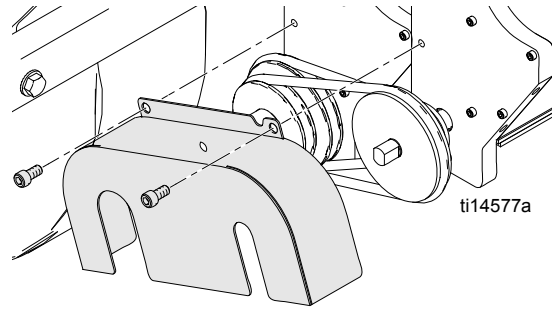

10. Align pulleys as shown below and tighten screws.

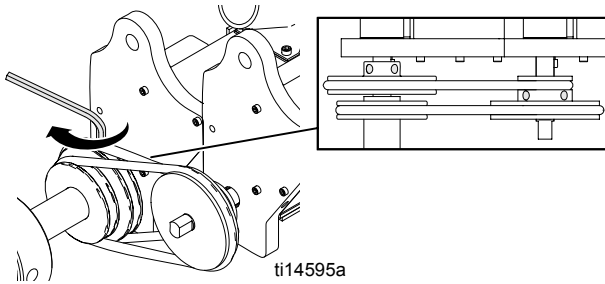

12. Reattach hose and tighten hose clamp.

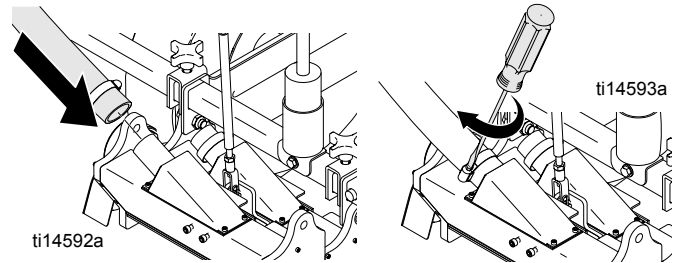

# Parts

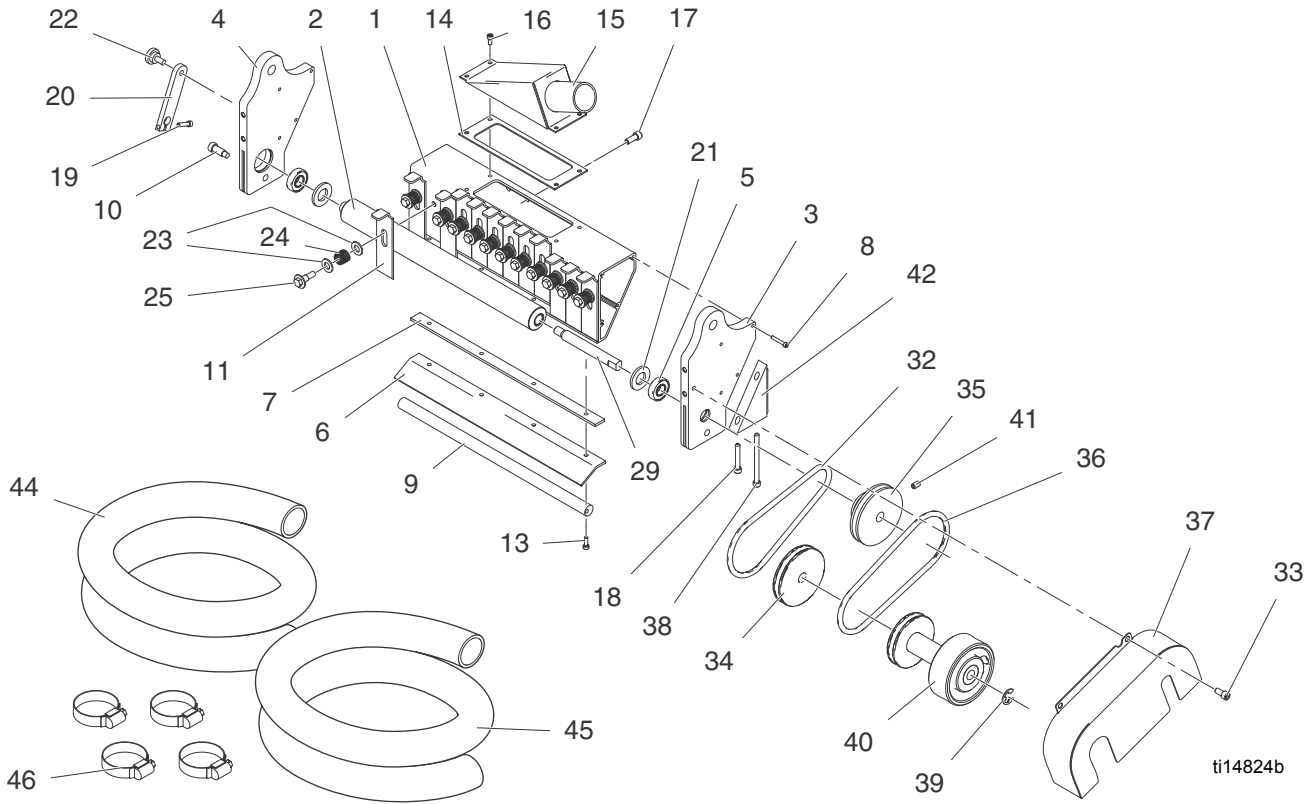

Ref.	Part	Description	Qty.	Ref.	Part	Description	Qty.
1	16U613	HOUSING, dispenser 12", 12 holes	1	22	123261	SCREW, thumb	1
2	16A333	SHAFT, knurled	1	23	104034	WASHER, plain	8
3	16H293	BRACKET, right	1	24	114708	SPRING, compression	4
4	16H292	BRACKET, left	1	25	119872	SCREW, shoulder	4
5	123304	BEARING, double sealed	2	29	16A805	SHAFT, short	1
6	15X274	GATE, poly	1	32	123527	BELT, inner	1
7	15X275	GATE, bar	1	33	101550	SCREW, cap, sch	2
8	110631	SCREW, socket, hd	8	34	16A803	PULLEY, large	1
9	15X281	ADJUSTER	1	35	16A802	PULLEY, double	1
10	123481	SCREW, shoulder, screw, 1/4-20	2	36	123526	BELT, outer	1
11	16U612	PLATE, slide 1"	12	37	16A807	GUARD, belt	1
13	112310	SCREW, cap, sch	4	38	514930	SCREW, cap, skt hd	2
14	16A243	GASKET, foam	1	39	113983	RING, retaining, ext.	1
15	257378	MANIFOLD, assembly	1	40	16A798	WHEEL, pulley, weldment	1
16	112788	SCREW, cap, socket hd	4	41	100050	SCREW, set, sch	4
17	121112	SCREW, cap, socket head	2	42	16A804	INSERT, bead box	2
18	104705	SCREW, cap, sch	2	44	16A994	HOSE, beads	1
19	295709	SCREW, cap, sockethead	1	45	16A996	HOSE, beads	1
20	15X282	HANDLE, adjuster	1	46	116789	CLAMP, hose	4
21	114797	GASKET	2				

All written and visual data contained in this document reflects the latest product information available at the time of publication.  
 Graco reserves the right to make changes at any time without notice.  
 For patent information, see [www.graco.com/patents](http://www.graco.com/patents).

Original instructions. This manual contains English. MM 3A0004A

**Graco Headquarters:** Minneapolis  
**International Offices:** Belgium, China, Japan, Korea

**GRACO INC. AND SUBSIDIARIES • P.O. BOX 1441 • MINNEAPOLIS MN 55440-1441 • USA**  
**Copyright 2009, Graco Inc. All Graco manufacturing locations are registered to ISO 9001**

[www.graco.com](http://www.graco.com)  
 Revised February 2013