

LazerVac™ and Cyclone

3A5577F

EN

Vacuum for collection of dry concrete and asphalt dust. For professional use only.

Vacuum Model 25M860 - LazerVac 550 (gasoline)
Separator Model 25M862 - Cyclone 32 (32 gallon) Model 25R090 - Cyclone LP



Important Safety Instructions

Read all warnings and instructions in this manual before using the equipment. Be familiar with the controls and the proper usage of the equipment. Save these instructions.

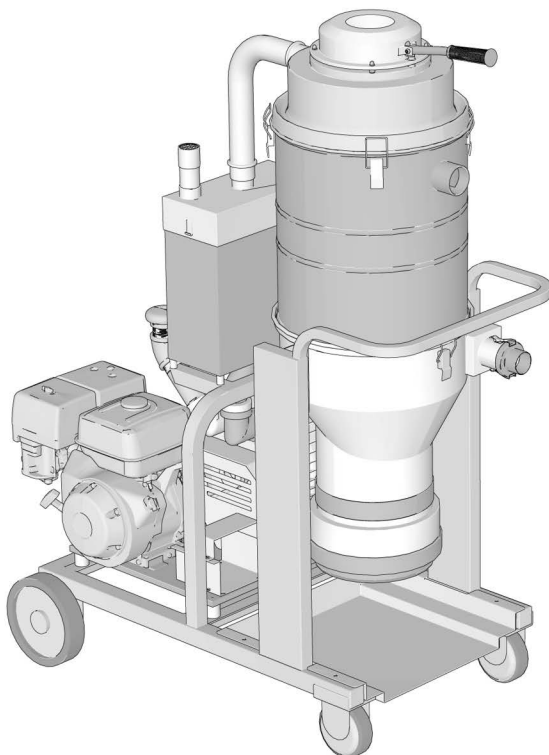

LazerVac 550

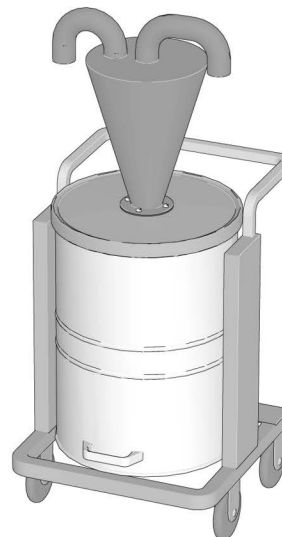

Cyclone 32

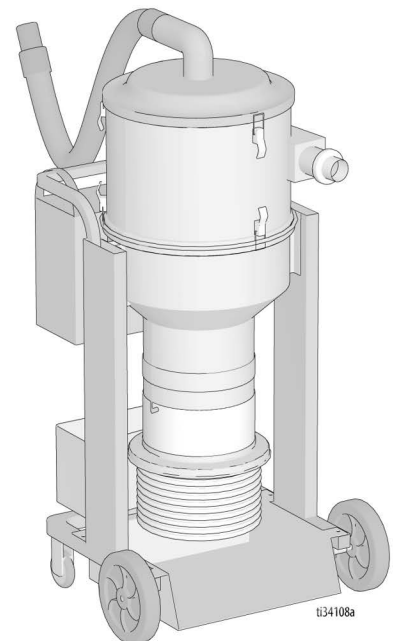

Cyclone LP









Contents

Warnings	3
Component Identification	5
LazerVac 550	5
Cyclone 32	5
Cyclone LP	5
Setup	6
Operation	7
Emptying Collection Tanks and Bags	8
Shutdown and Storage	9
Shutdown	9
Storage	9
Maintenance and Repair	10
Maintenance	10
Repair	10
Recycling and Disposal	13
Rechargeable Battery Disposal	13
End of Product Life	13
Parts	14
Main Assembly Diagram (LazerVac 550)	14
Main Assembly Parts (LazerVac 550)	15
Accessories Diagram (LazerVac 550)	16
Accessories Parts List (LazerVac 550)	16
Lid and Vacuum Release Assembly Diagram (LazerVac 550)	17
Lid and Vacuum Release Assembly Parts List (LazerVac 550)	17
Filter Bag Assembly Diagram (LazerVac 550)	18
Filter Bag Assembly Parts List (LazerVac 550)	18
Air Filter Assembly Diagram (LazerVac 550)	19
Air Filter Assembly Parts List (LazerVac 550)	19
Cyclone 32 Assembly and Accessories Diagram	20
Cyclone 32 Assembly and Accessories Parts List	21
Cyclone LP Assembly and Accessories	22
Cyclone LP Assembly and Accessories Parts List	23
Technical Data	24
California Proposition 65	24
Graco Standard Warranty	25

Warnings

The following warnings are for the setup, use, grounding, maintenance, and repair of this equipment. The exclamation point symbol alerts you to a general warning and the hazard symbols refer to procedure-specific risks. When these symbols appear in the body of this manual or on warning labels, refer back to these Warnings. Product-specific hazard symbols and warnings not covered in this section may appear throughout the body of this manual where applicable.

 <h2 style="margin: 0;">WARNING</h2>	
	<p>DUST HAZARD</p> <p>Grinding concrete and other surfaces can create dust that contains hazardous substances. To reduce the risk of serious injury:</p> <ul style="list-style-type: none"> • Control the dust to meet all applicable workplace regulations. • Wear a properly fit-tested and government approved respirator suitable for the dust conditions when emptying collection tank or performing maintenance. • Do not use without dust bag and filters in place.
	<p>EQUIPMENT MISUSE HAZARD</p> <p>Misuse can cause death or serious injury.</p> <ul style="list-style-type: none"> • Do not operate the unit when fatigued or under the influence of drugs or alcohol. • Do not leave the work area while equipment is energized. Turn off all equipment when equipment is not in use. • Check equipment daily. Repair or replace worn or damaged parts immediately with genuine manufacturer's replacement parts only. • Do not alter or modify equipment. • Use equipment only for its intended purpose. Call your distributor for information. • Keep children and animals away from work area. • Comply with all applicable safety regulations. • Maintain a safe operating distance from other people in the work area.
	<p>ENTANGLEMENT HAZARD</p> <p>Rotating parts can cut or amputate fingers and other body parts.</p> <ul style="list-style-type: none"> • Keep clear of rotating parts. • Do not operate equipment with protective guards or covers removed. • Do not wear loose clothing, jewelry or long hair while operating equipment. • Disconnect battery before checking, moving, or servicing the equipment.
	<p>BURN HAZARD</p> <p>Blower, diffuser and engine can become very hot during operation. To avoid severe burns, do not touch hot equipment.</p>
	<p>PERSONAL PROTECTIVE EQUIPMENT</p> <p>You must wear appropriate protective equipment when operating, servicing, or when in the operating area of the equipment to help protect you from serious injury, inhalation of dust or chemicals, and hearing loss. This equipment includes but is not limited to:</p> <ul style="list-style-type: none"> • Protective eye wear. • Hearing protection. • Properly fit-tested and government approved respirator suitable for the dust conditions.



WARNING



FIRE AND EXPLOSION HAZARD

Flammable fumes in work area can ignite or explode. To help prevent fire and explosion:

- Do not use to pick up flammable or combustible liquids, such as gasoline, or use in areas where they may be present.
- Use equipment only in well ventilated area.
- Do not fill fuel tank while engine is running or hot; shut off engine and let it cool. Fuel is flammable and can ignite or explode if spilled on hot surface.
- Keep work area free of debris, including solvent, rags and gasoline.
- Keep a fire extinguisher in work area.



CARBON MONOXIDE HAZARD

Exhaust contains poisonous carbon monoxide, which is colorless and odorless. Breathing carbon monoxide can cause death.

- Do not operate in an enclosed area.



BATTERY HAZARD

Lead-acid batteries produce explosive gases and contain sulfuric acid that can cause severe burns. To avoid sparks and injury when handling or working with a lead-acid battery:

- Read and follow the battery manufacturer's warnings.
- Exercise caution when working with metallic tools or conductors to prevent short circuits and sparks.
- Keep all sparks, flames, and cigarettes away from batteries.
- Always wear protective eyewear and protective equipment for face, hands, and body.
- If you have direct contact with battery fluid, flush with water and consult a physician immediately.
- Installation and maintenance must be performed by knowledgeable personnel only.

Component Identification

LazerVac 550

Cyclone 32

Cyclone LP

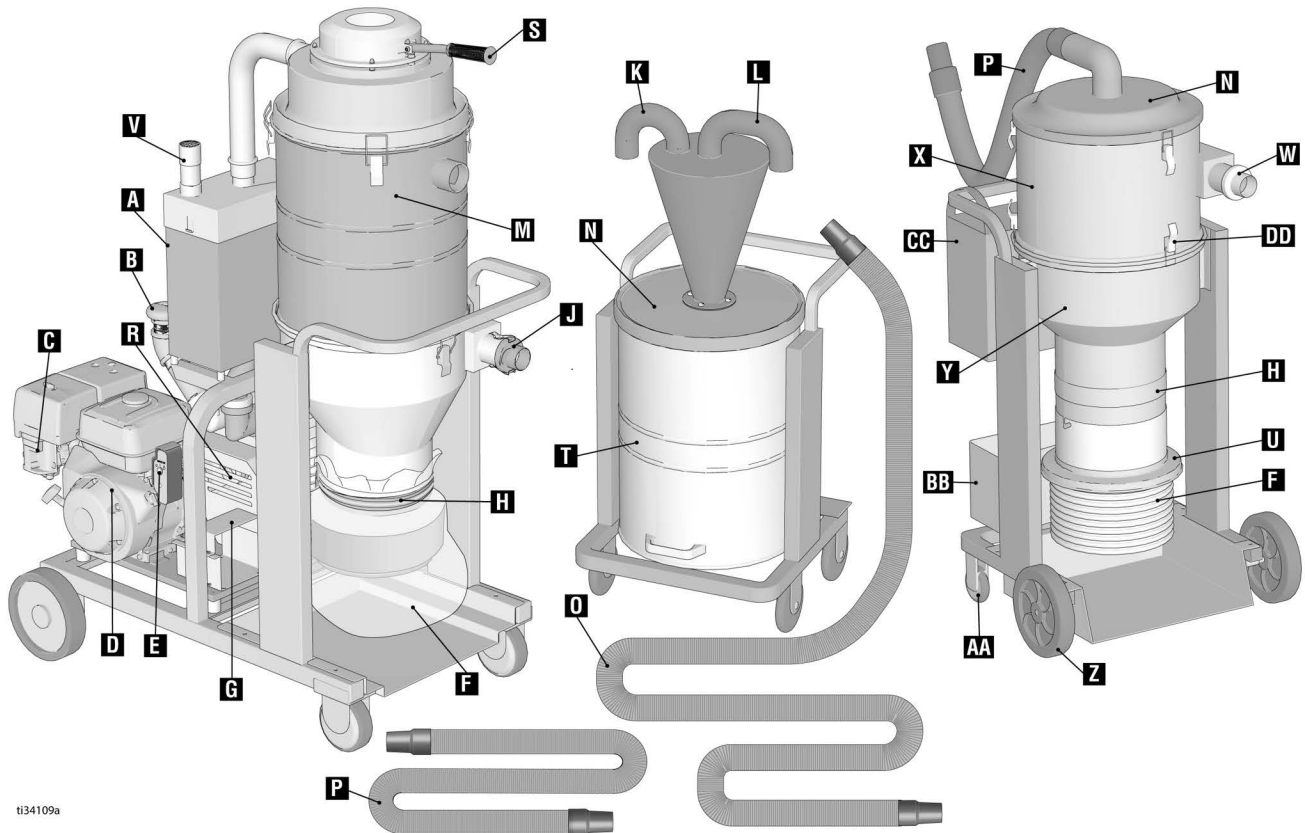

ti34109a

	Component
A	Air Filter Housing
B	Diffuser
C	Engine Choke, Fuel Valve, and Throttle Control
D	Engine
E	Electric Start Key
F	Vacuum Dust Collection Bag
G	Battery
H	Velcro® Belt (to secure Vacuum Dust Collection Bag)
J	Vacuum Hookup
K	Vacuum Inlet
L	Vacuum Outlet
M	Main Housing (contains Filter Bags)
N	Separator Lid
O	Long Hose (to connect the LazerVac or Cyclone to the GrindLazer)

	Component
P	Short Hose (to connect the LazerVac to the Cyclone)
R	Blower
S	Vacuum Release Handle
T	Dust Collection Tank (Dust Bag Holder is inside tank, not shown)
U	Bag Adapter
V	Relief Valve (protects air filters from damage)
W	GrindLazer Hookup
X	Separator Mid Body
Y	Separator Lower Body
Z	10" Wheel
AA	4" Wheel
BB	Tool Box
CC	Tool Bag
DD	Drum Latch

Setup

1. Install dust collection bags onto vacuum and into separator.
 - a. Slide the Vacuum Dust Collection Bag onto the Continuous Dust Bag Adapter. Install the bag assembly onto the bottom of the Main Housing of the LazerVac. Wrap the Velcro Belt around the top of the bag to ensure an air tight seal. Pull enough bag down to rest on the bottom of the vacuum cart, then tie a cable tie around the bottom of the bag.

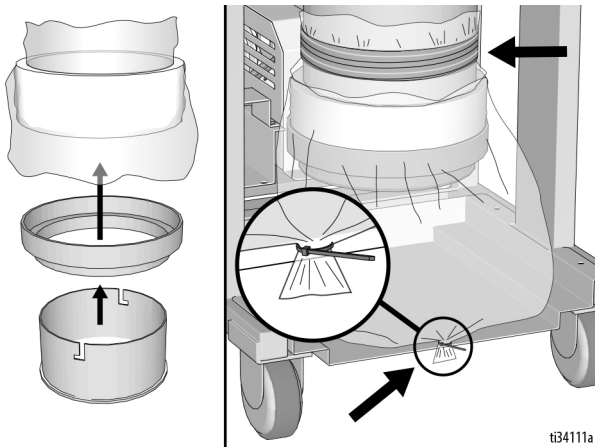

ti34111a

- b. If using a Cyclone separator, remove the Separator Lid and insert the Dust Bag into the tank. Insert the Dust Bag Holder into the bag. Wrap the bag around the lip of the tank and reinstall the Separator Lid onto the tank.

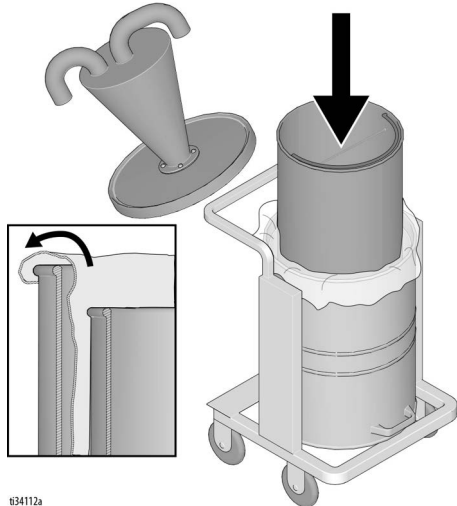

ti34112a

2. Connect hoses.

If using a Cyclone separator:

- Connect one end of the Short Vacuum Hose to the inlet of the LazerVac. Connect the other end of the Short Vacuum Hose to the outlet of the Cyclone separator.
- Connect one end of the Long Vacuum Hose to the inlet of the Cyclone separator. Connect the other end of the Long Vacuum Hose to the vacuum hookup on the GrindLazer.

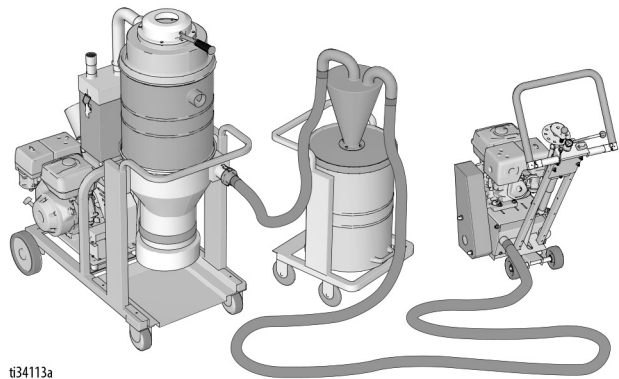

ti34113a

If not using a Cyclone separator:

- Connect one end of the Long Vacuum Hose to the inlet of the LazerVac. Connect the other end of the Long Vacuum Hose to the vacuum hookup on the GrindLazer.

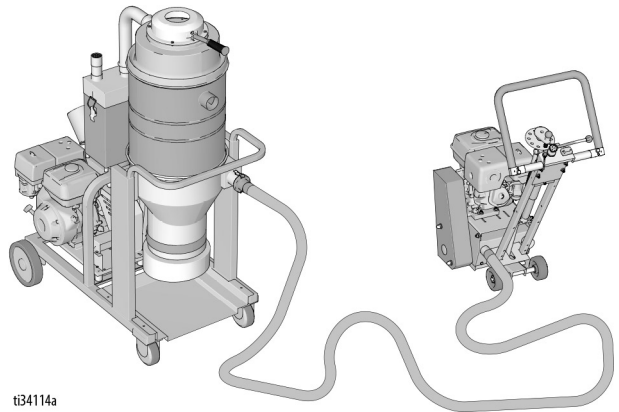

ti34114a

NOTE: Use the Y-Connector to connect 2 hoses to the vacuum or separator, if desired.

Operation



1. Slide the Fuel Valve on the engine to ON.

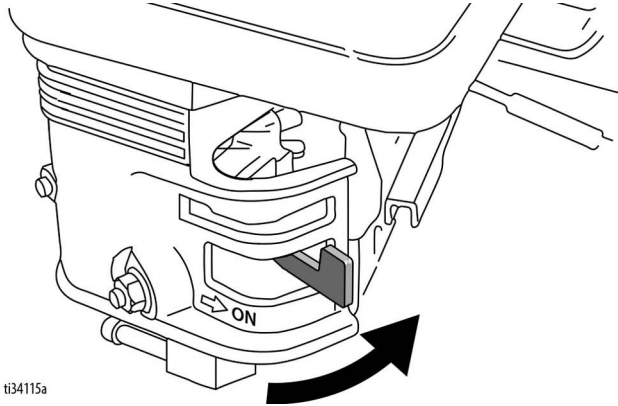

2. Slide the Engine Choke to closed.

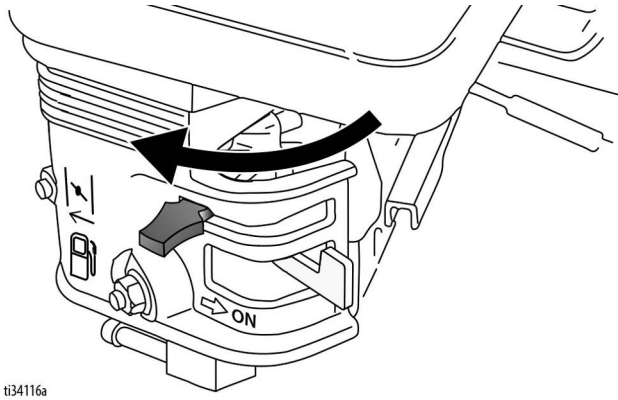

3. Adjust the Throttle Control to 1/3 speed setting.

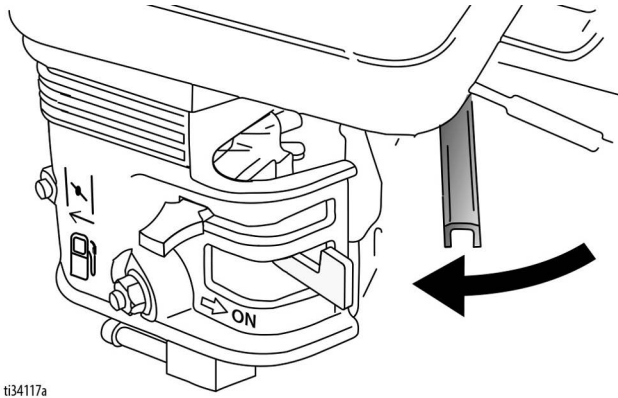

4. Turn the Electric Start Key to START.

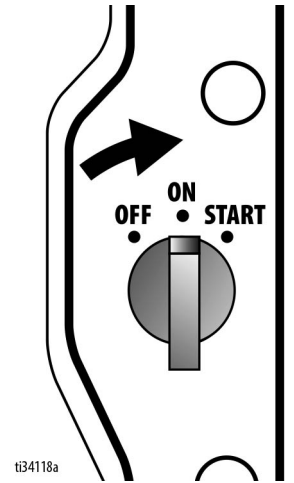



5. After the engine warms up, move Engine Choke to open and adjust the Throttle Control to the desired speed.

6. LazerVac is now ready for dust collection from the GrindLazer.

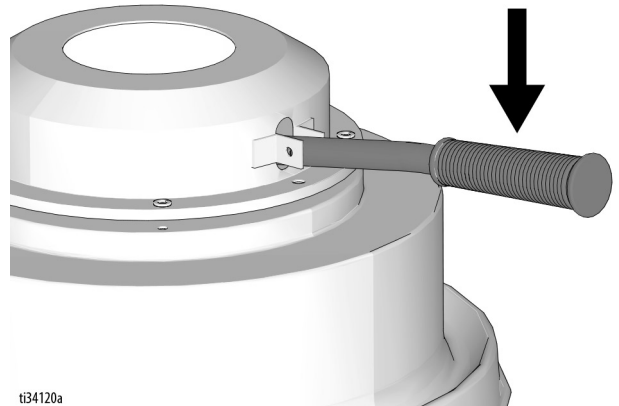
7. To help ensure proper dust collection, momentarily pull down on the Vacuum Release Handle every 10 minutes of operation while the LazerVac engine is running. This helps clean the Filter Bags from accumulated dust and debris, and transfers them to the Vacuum Dust Collection Bag.



Emptying Collection Tanks and Bags

				
<p>DUST HAZARD Grinding concrete and other surfaces can create dust that contains hazardous substances. To reduce the risk of serious injury:</p> <ul style="list-style-type: none"> • Respirator must be worn when emptying or cleaning Dust Collection Tanks or bags. • Follow local ordinances and regulations for disposal. 				

Cyclone Separator

1. When Dust Collection Tank is full, turn off vacuum. Put on respirator. Remove the Separator Lid and the Dust Bag Holder from the tank.
2. Gather and secure the top of the collection bag. Lift and remove the collection bag, tie up and then dispose. Follow local ordinances and regulations for disposal.

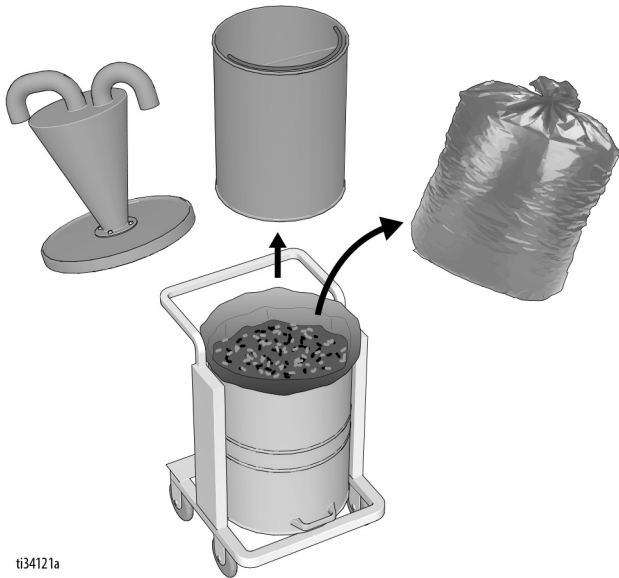

3. Insert new bag into collection tank and reinstall the Dust Bag Holder and Separator Lid onto the tank.

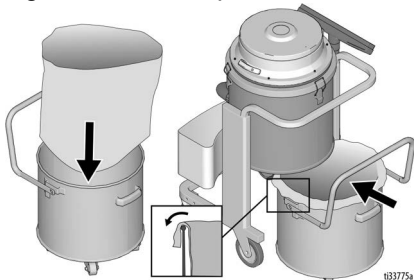

LazerVac and Cyclone LP

1. When Vacuum Collection Bag has collected approximately 45 lbs (20 kg) of dust, the bag should be replaced. Momentarily pull down on the Vacuum Release Handle, then turn the LazerVac off.
2. Pull down on the continuous bag to expose 6 - 12" (15 - 30 cm) of new, unused bag.
3. Use a cable tie to tie off the top of the bag. Fasten another cable tie 2" (5 cm) cable tie above the first cable tie.
4. Put on respirator. Cut the bag between the two cable ties.

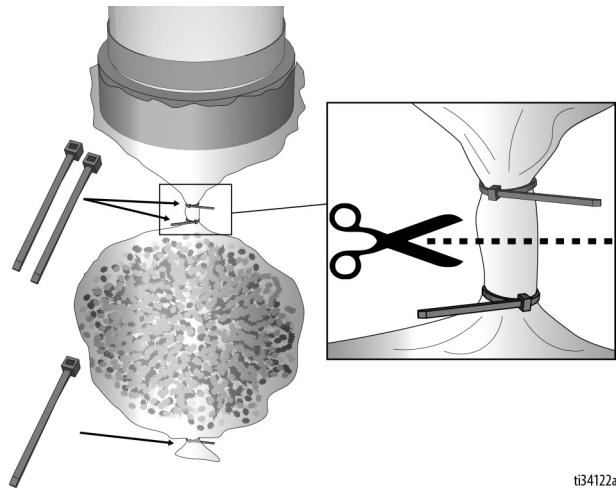

5. Dispose of the dust bag. Follow local ordinances and regulations for disposal.
6. Pull down on the new bag attached to the vacuum until the bottom of the bag rests on the bottom of the vacuum cart. Ensure the bottom of the bag is tied off firmly with the cable tie.

Shutdown and Storage

Shutdown

1. While the engine is running, momentarily pull down on the Vacuum Release Handle.

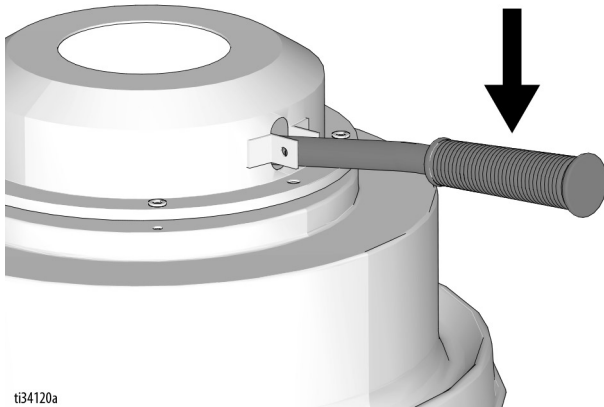

ti34120a

2. Move Throttle Control to the minimum setting.

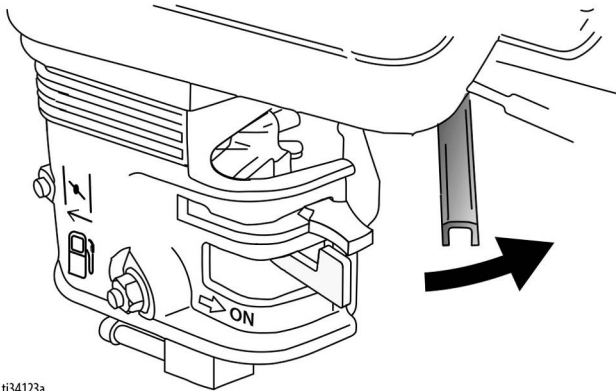

ti34123a

3. Turn the Electric Start Key to OFF.

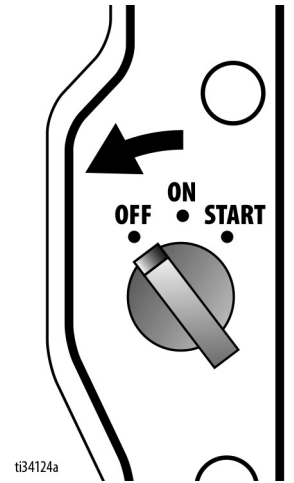

ti34124a

Storage

Slide Fuel Valve on the engine to OFF. Store indoors.

NOTICE

Do not store in a location with high temperatures or excessive humidity, in order to prevent damage to your LazerVac components.

Maintenance and Repair



				
<p>To reduce the risk of serious injury:</p> <ul style="list-style-type: none"> • Respirator must be worn during all maintenance and repair. • Follow local ordinances and regulations for disposal of dust. • Disconnect spark plug wire and black cable from battery before maintenance. 				

Maintenance

The following steps should be performed to help maintain proper operation and sustain the life of the LazerVac.

Daily

- Prior to use, inspect all hoses for holes. Repair or replace damaged hoses.
- To help maintain performance and dust control, replace bag filters and/or air filters when:
 - Filters have tears or are clogged.
 - Airborne dust is visible when using the LazerVac.
 - Airborne dust exits the Diffuser when using the LazerVac.
- Check belt tension for slipping and/or excessive wear. Tighten or replace belt if needed.
- Verify that the Relief Valve does not open when the engine is running. If the Relief Valve opens, clean or replace the air filters.

				
<p>DUST HAZARD Vacuum performance will deteriorate if the drive belt has excessive wear or is not properly tensioned.</p>				

Weekly

Inspect seals for damage. If damaged, replace seal. Ensure seals are installed correctly and properly sealed.

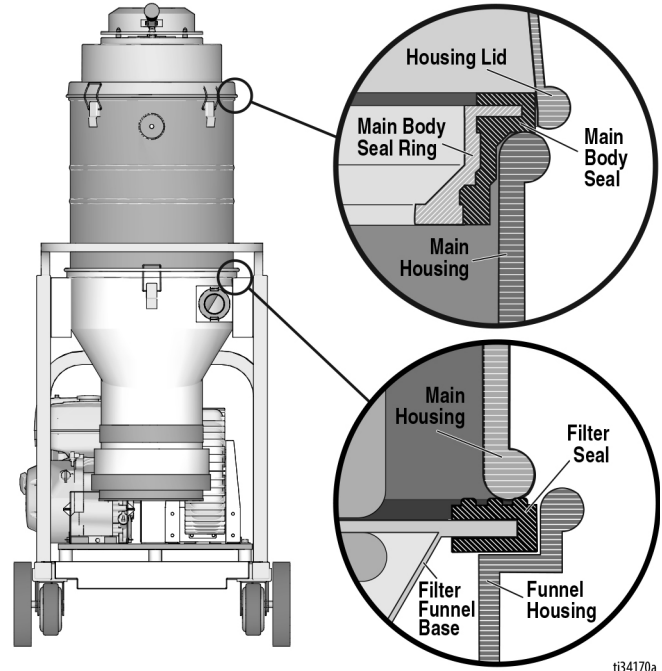

Repair

Filter Bag Replacement

1. Unlatch the Drum Latches from the Main Housing in order to access the Filter Bags. Lift off the Housing Lid.

- Untie knots from the top of the Filter Bags.

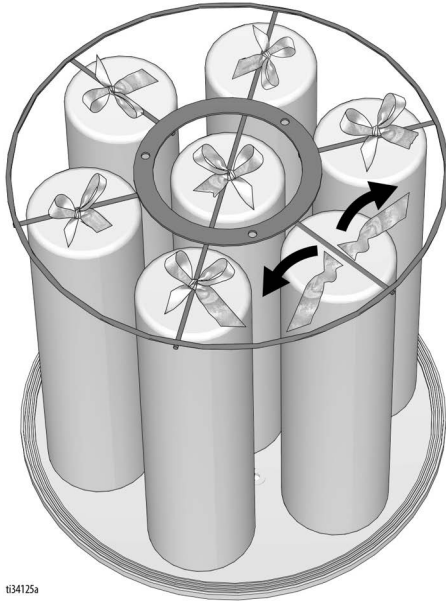

- Press wire form at the bottom of the Filter Bag.

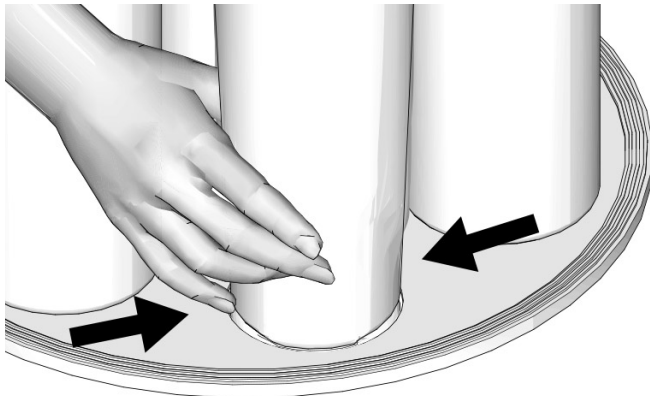

- Separate filter from hole by lifting up on the Filter Bag.

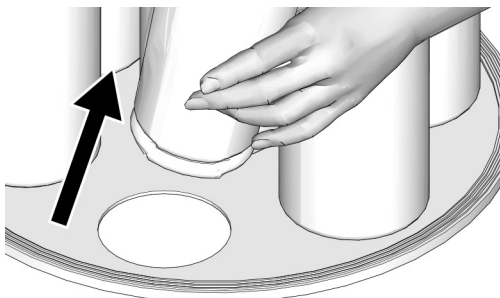

- Remove old Filter Bag from the vacuum.

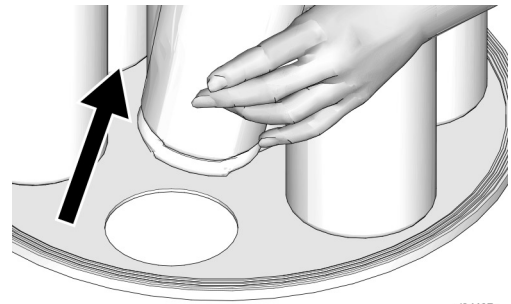

- Insert new Filter Bag and tie a knot from the new Filter Bag onto the top wire rack.

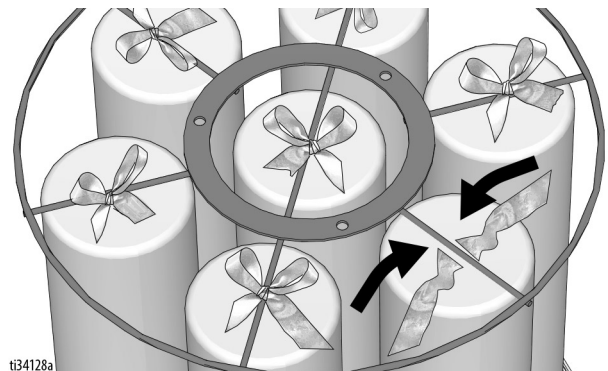

- Press wire and insert new Filter Bag into hole.

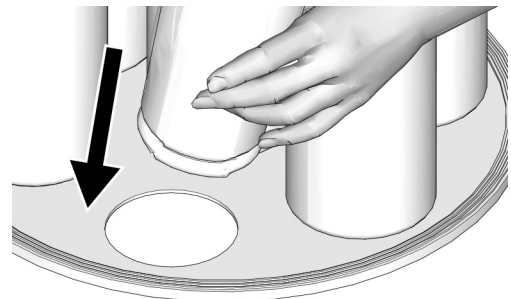

- Ensure seals are installed correctly and properly sealed when reassembling the Main Housing.

V-Belt Replacement and Tensioning

Follow these instructions to install a new V-Belt, or to re-tension current belts.

1. Loosen the four bolts (labeled "A") that secure the Blower to the mounting plate.

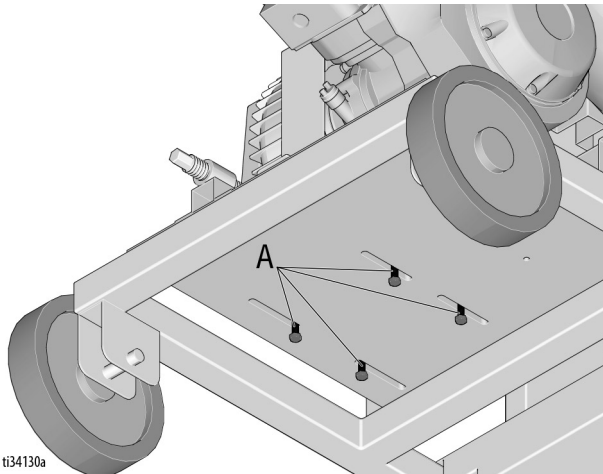

2. Loosen the two bolts (labeled "B") and remove Belt Guard.

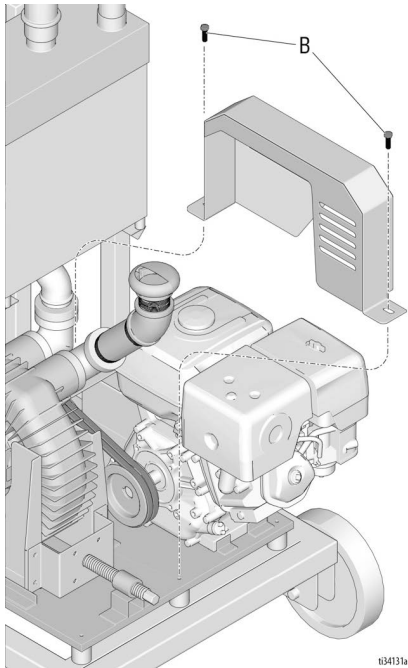

3. To install a new V-Belt, use a 3/4" hex wrench on "C" to move the Blower Pulley closer to the Engine Pulley. Replace the belt.

4. To tension the belt, use a 3/4" hex wrench on "C" to move the Blower Pulley away from the Engine Pulley. Keep tightening the belt until the belt deflects approximately 1/8" (3mm) when squeezed by hand.

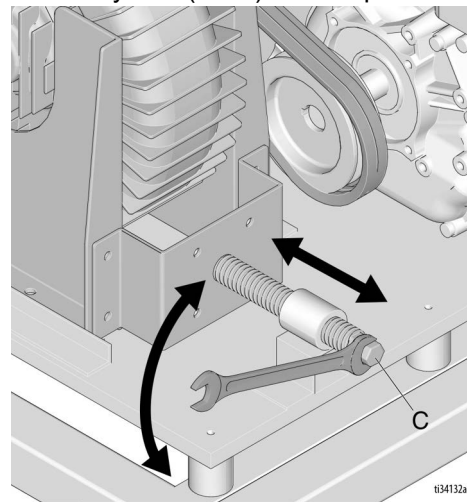

5. Ensure pulleys are aligned after tensioning. If they are not aligned, release the belt tension, loosen the Engine Pulley set screws and align the pulleys. Check alignment after tensioning the V-Belt.

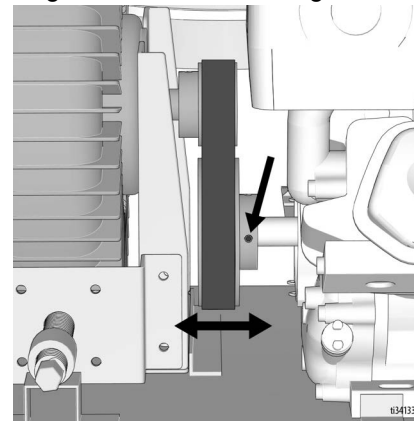

6. When the V-Belt is properly aligned and tensioned, tighten the four bolts (labeled "A") to secure the Blower to the mounting plate. Reassemble the Belt Guard with the two bolts (labeled "B" in step 2).

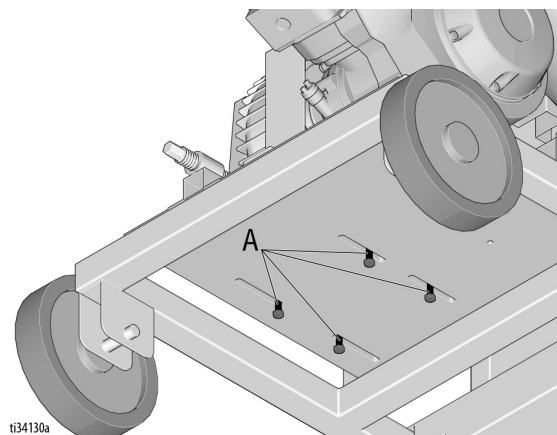

Recycling and Disposal

Rechargeable Battery Disposal

Do not place batteries in the trash. Recycle batteries according to local regulations. In the USA and Canada, call 1-800-822-8837 to find recycling locations or go to www.call2recycle.org.

Do not place batteries in the trash. Recycle batteries according to local regulations.

End of Product Life

At the end of a product's useful life, recycle it in a responsible manner.

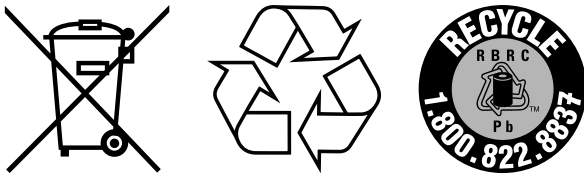

Parts

Main Assembly Diagram (LazerVac 550)

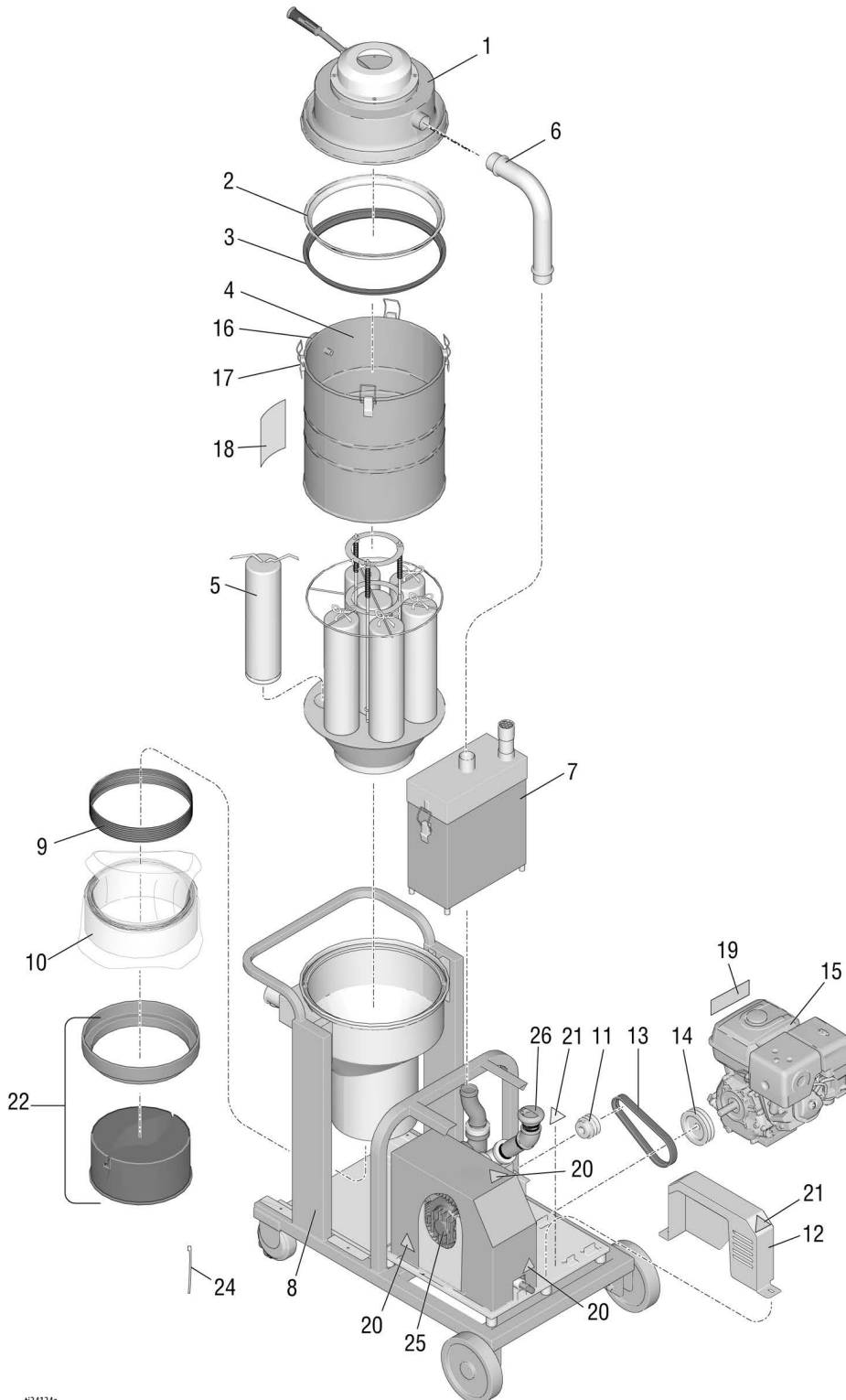

t334134a

Main Assembly Parts (LazerVac 550)

Ref	Part Number	Description	Qty
1	see page 17	Lid and Vacuum Release Plunger	1
2	17X196	Main Body Seal	1
3	17X197	Main Body Seal Ring	1
4	17X198	Filter Housing/Main Body	1
5	see page 18	Filter Bag Assembly	1
6	17X199	Coupler Hose	1
7	see page 19	Filter Housing Assembly	1
8	17X200	Main Frame	1
9*	17X154	Velcro Belt	1
10*	17W295	Vacuum Dust Collection Bag (Continuous, 20 meters)	1
11	17W966	Blower Pulley, 3"	1
	17X927	Bushing, Blower Pulley	1
12	17X202	Belt Guard	1
13	17X924	V-Belt	1
14	17X925	Engine Pulley, 5"	1
	17X926	Bushing, Engine Pulley	1
15	17W422	13 hp Honda Engine	1
16	17X204	Vacuum Gauge	1
17	17X205	Drum Latch	7
18 ▲	17W132	Warning Label, Multiple, Icons	1
19 ▲	194126	Warning, Fire and Explosion	1
20 ▲	16D646	Warning, Hot Surface	3
21 ▲	16C394	Warning, Entanglement	2
22	17X930	Continuous Dust Bag Adapter	1
24	N/A	Cable Ties (to tie off bag)	N/A
25	17X928	Blower	1
26	17Y255	Exhaust Diffuser	1
27	115753	33 Amp-Hour Sealed Battery (not shown)	1

▲ Replacement warning, safety labels, tags, and cards are available at no cost.

* LazerVac 550 is shipped with one spare each of items 9 and 10.

Accessories Diagram (LazerVac 550)

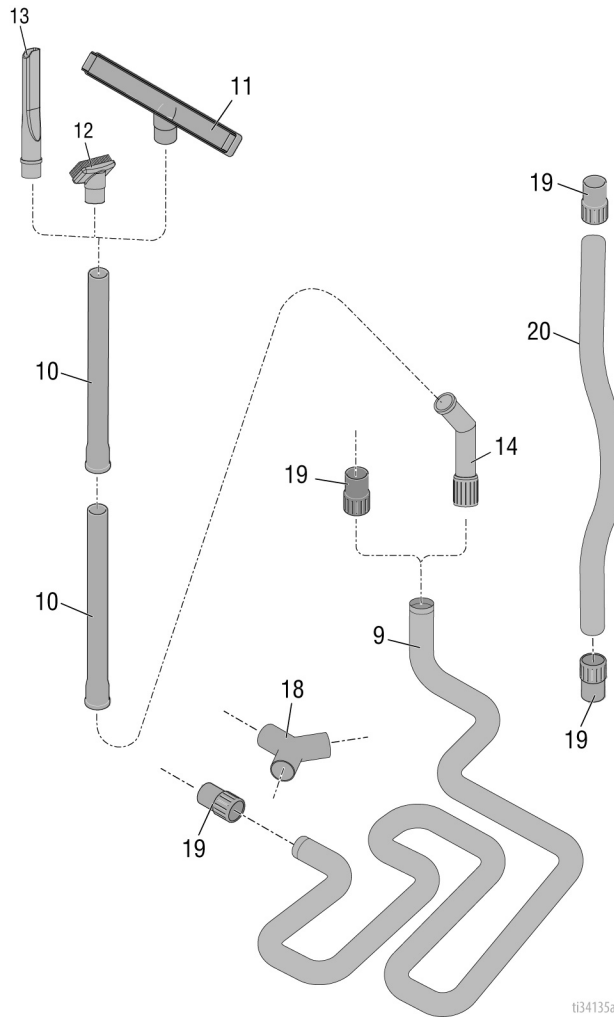

ti34135a

Accessories Parts List (LazerVac 550)

	Part Number	Description	Qty
9	17X156	Long Vacuum Hose, Standard, 2" (includes item 19)	1
	17X704	Long Vacuum Hose, Heavy Duty, High Temp, 2"	1
10	17X158	Vacuum Extension (set of 2)	1
11	17X162	Vacuum Large Brush	1
12	17X161	Vacuum Small Brush	1
13	17X160	Vacuum Floor Nozzle	1
14	17X159	Vacuum Elbow	1
18	17X163	Y-Connector	1
19	17X164	2" Hose Connector for Standard Hose (LazerVac is shipped with 2 extra connectors)	4
20	17X693	Short Vacuum Hose, Standard, 2" (includes item 19)	1
	17W154	Short Vacuum Hose, Heavy Duty, High Temp, 2"	1

Lid and Vacuum Release Assembly Diagram (LazerVac 550)

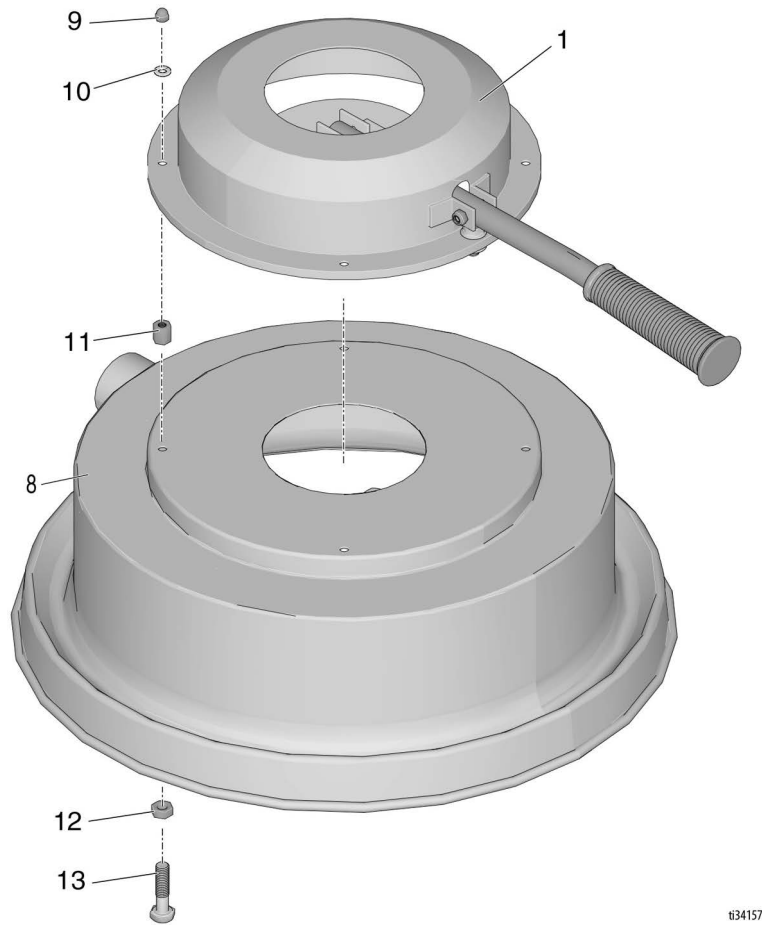

Lid and Vacuum Release Assembly Parts List (LazerVac 550)

	Part Number	Description	Qty
1	17X220	Vacuum Release Handle Assembly	1
8	17X227	Lower Lid	1
9	17X168	1/4-20 Acorn Nut	4
10	17W228	1/4" Lock Washer	4
11	17X174	1/4-20 Coupling Nut	4
12	17W259	1/4-20 Hex Nut	4
13	17X233	1/4-20x1 1/4 Hex Head Bolt	4

Filter Bag Assembly Diagram (LazerVac 550)

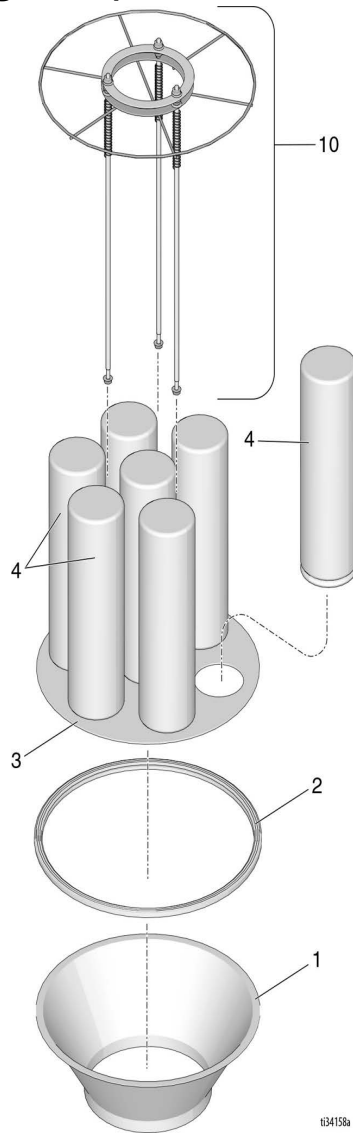

Filter Bag Assembly Parts List (LazerVac 550)

	Part Number	Description	Qty
1	17X235	Filter Funnel Base	1
2	17X236	Filter Seal	1
3	17X237	Filter Base Plate	1
4	17X238	Filter Bag (set of 7)	1
10	17X244	Wire Net and Spring Kit	1

Air Filter Assembly Diagram (LazerVac 550)

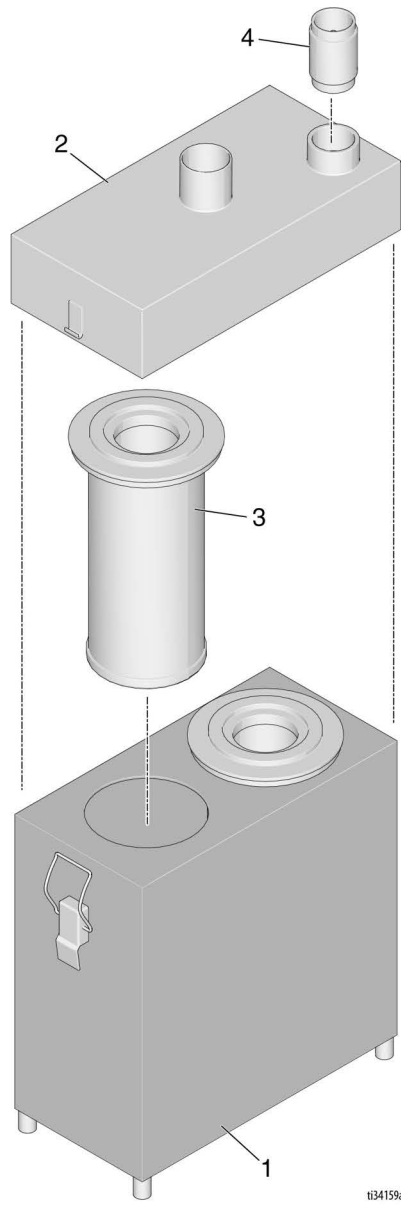

Air Filter Assembly Parts List (LazerVac 550)

	Part Number	Description	Qty
1	17X245	Filter Main Casing	1
2	17X246	Filter Casing Lid	1
3*	17X247	Air Filter, set of 2	1
4	17X248	Relief Valve	1
*HEPA Filter Set available (17Y254)			

Cyclone 32 Assembly and Accessories Diagram

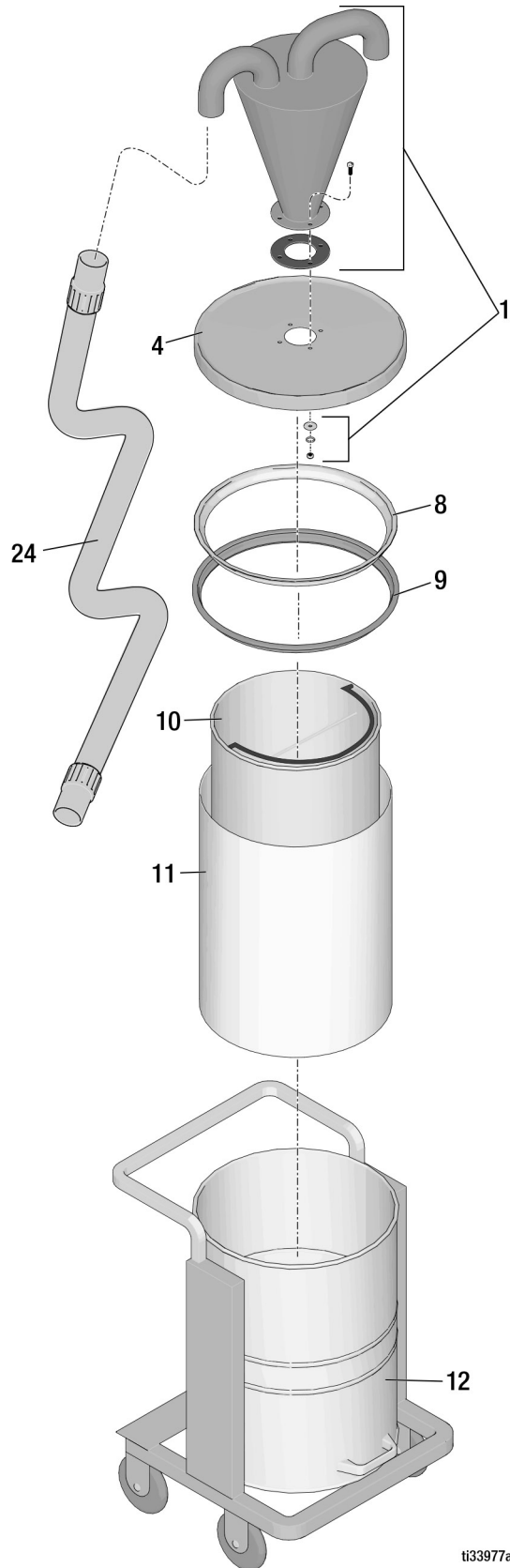

ti33977a

Cyclone 32 Assembly and Accessories Parts List

	Part Number	Description	Qty
1	17X206	Lid Funnel	1
4	17X209	Lid Base	1
8	17X196	Cyclone Ring, Metal	1
9	17X197	Cyclone Seal, Rubber	1
10	17X215	Dust Bag Holder	1
11	17X216	Dust Bag (35" x 47") (set of 20)	1
12	17X217	Separator Main Frame	1
24*	17X693	Short Vacuum Hose, Standard 2" (to connect to LazerVac)	1

* 2" Heavy Duty, High Temperature Hose Available (P/N 17W154)

Cyclone LP Assembly and Accessories

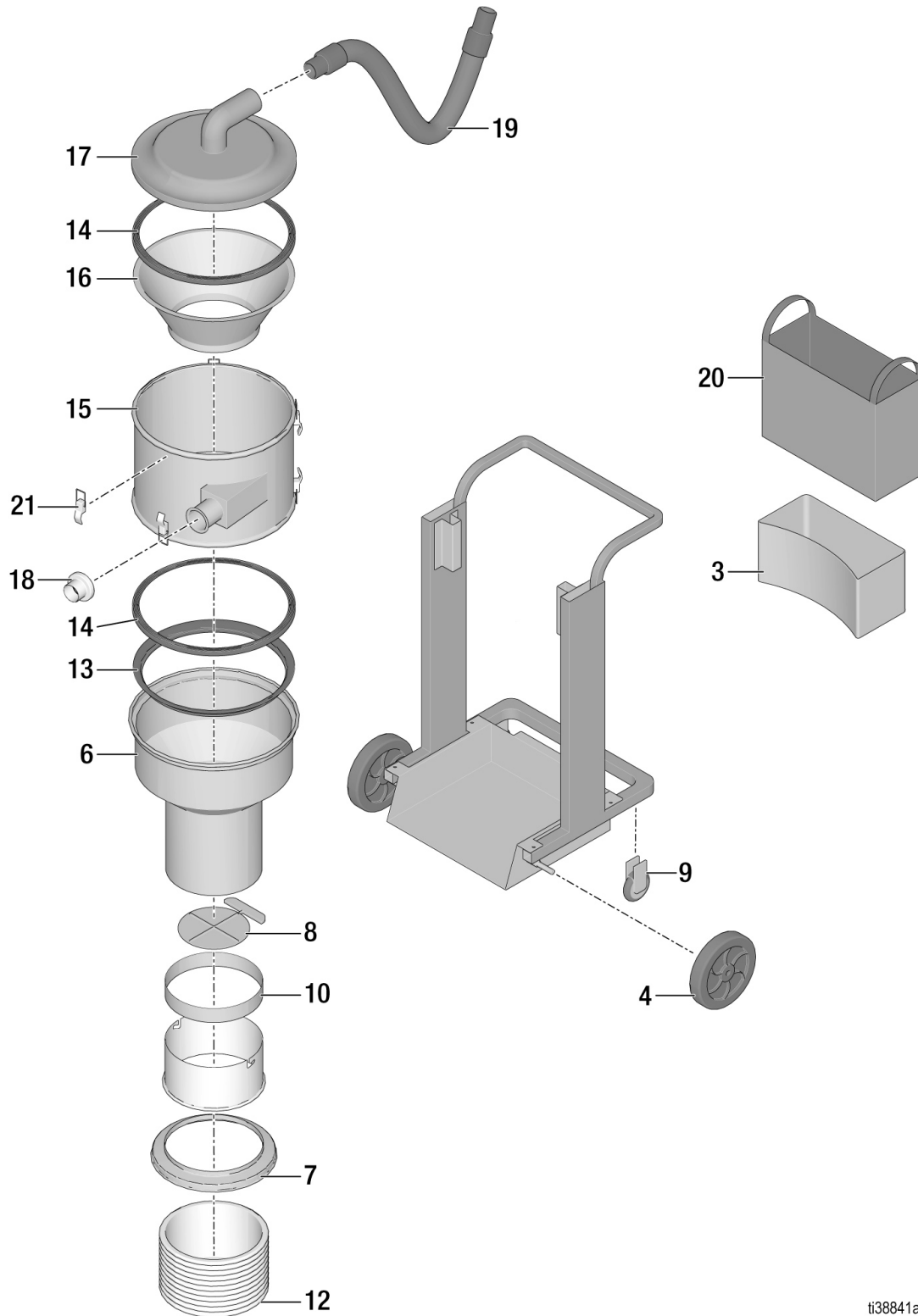

i38841a

Cyclone LP Assembly and Accessories Parts List

	Part Number	Description	Qty
3	19B348	Tool Box	1
4	19B345	10" Wheel	2
6	19B344	Separator Lower Body	1
7	17X930	Bag Adapter	1
8	19B350	Dust Flap Cover	1
9	19B346	4" Caster	2
10	17X154	Belt (to secure Vacuum Dust Collection Bag)	1
12	17W295	Plastic Bag	1
13	17X196	Metal Ring (main body seal)	1
14	17X197	Rubber Seal (main body)	2
15	19B343	Separator Mid Body	1
16	17X235	Base Filter Funnel	1
17	19B342	Lid	1
18	19B341	Hose Inlet	1
19*	17X693	Vacuum Hose, short	1
20	19B779	Tool Bag	1
21	17X205	Drum Latch	6
* 2" Heavy Duty, High Temperature Hose available: P/N 17W154			

Technical Data

LazerVac 550 (25M860), 13 HP Gasoline		
Air Flow (full throttle, without hose) - 295 cfm (501 m ³ /hour)		
Air Flow (full throttle, with 2" x 30' hose, no Y-Connector) - 216 cfm (367 m ³ /hour)		
Vacuum Pressure (no flow) - 148" H ₂ O (276 mm Hg, 0.37 bar)		
Maximum Air Power (without hose) - 2045 Air-Watts		
Filtration - 99.3% at 0.3 µm particle size		
Dimensions/Weight (unpackaged)	US	Metric
LazerVac 550 (25M860)		
Height	72 in.	183 cm
Length	48 in.	122 cm
Width	35 in.	89 cm
Weight	575 lb	260 kg
Cyclone 32 (25M862)		
Height	58 in.	147 cm
Length	26 in.	66 cm
Width	26 in.	66 cm
Weight	90 lb	41 kg
Cyclone LP (25R090)		
Height	62 in.	157 cm
Length	28 in.	71 cm
Width	32 in.	81 cm
Weight	125 lb	57 kg

All trademarks or registered trademarks are the property of their respective owners.

California Proposition 65

CALIFORNIA RESIDENTS

 **WARNING:** Cancer and reproductive harm – www.P65warnings.ca.gov.

Graco Standard Warranty

Graco warrants all equipment referenced in this document which is manufactured by Graco and bearing its name to be free from defects in material and workmanship on the date of sale to the original purchaser for use. With the exception of any special, extended, or limited warranty published by Graco, Graco will, for a period of twelve months from the date of sale, repair or replace any part of the equipment determined by Graco to be defective. This warranty applies only when the equipment is installed, operated and maintained in accordance with Graco's written recommendations.

This warranty does not cover, and Graco shall not be liable for general wear and tear, or any malfunction, damage or wear caused by faulty installation, misapplication, abrasion, corrosion, inadequate or improper maintenance, negligence, accident, tampering, or substitution of non-Graco component parts. Nor shall Graco be liable for malfunction, damage or wear caused by the incompatibility of Graco equipment with structures, accessories, equipment or materials not supplied by Graco, or the improper design, manufacture, installation, operation or maintenance of structures, accessories, equipment or materials not supplied by Graco.

This warranty is conditioned upon the prepaid return of the equipment claimed to be defective to an authorized Graco distributor for verification of the claimed defect. If the claimed defect is verified, Graco will repair or replace free of charge any defective parts. The equipment will be returned to the original purchaser transportation prepaid. If inspection of the equipment does not disclose any defect in material or workmanship, repairs will be made at a reasonable charge, which charges may include the costs of parts, labor, and transportation.

THIS WARRANTY IS EXCLUSIVE, AND IS IN LIEU OF ANY OTHER WARRANTIES, EXPRESS OR IMPLIED, INCLUDING BUT NOT LIMITED TO WARRANTY OF MERCHANTABILITY OR WARRANTY OF FITNESS FOR A PARTICULAR PURPOSE.

Graco's sole obligation and buyer's sole remedy for any breach of warranty shall be as set forth above. The buyer agrees that no other remedy (including, but not limited to, incidental or consequential damages for lost profits, lost sales, injury to person or property, or any other incidental or consequential loss) shall be available. Any action for breach of warranty must be brought within two (2) years of the date of sale.

GRACO MAKES NO WARRANTY, AND DISCLAIMS ALL IMPLIED WARRANTIES OF MERCHANTABILITY AND FITNESS FOR A PARTICULAR PURPOSE, IN CONNECTION WITH ACCESSORIES, EQUIPMENT, MATERIALS OR COMPONENTS SOLD BUT NOT MANUFACTURED BY GRACO. These items sold, but not manufactured by Graco (such as electric motors, switches, hose, etc.), are subject to the warranty, if any, of their manufacturer. Graco will provide purchaser with reasonable assistance in making any claim for breach of these warranties.

In no event will Graco be liable for indirect, incidental, special or consequential damages resulting from Graco supplying equipment hereunder, or the furnishing, performance, or use of any products or other goods sold hereto, whether due to a breach of contract, breach of warranty, the negligence of Graco, or otherwise.

FOR GRACO CANADA CUSTOMERS

The Parties acknowledge that they have required that the present document, as well as all documents, notices and legal proceedings entered into, given or instituted pursuant hereto or relating directly or indirectly hereto, be drawn up in English. Les parties reconnaissent avoir convenu que la rédaction du présente document sera en Anglais, ainsi que tous documents, avis et procédures judiciaires exécutés, donnés ou intentés, à la suite de ou en rapport, directement ou indirectement, avec les procédures concernées.

Graco Information

For the latest information about Graco products, visit www.graco.com.

For patent information, see www.graco.com/patents.

TO PLACE AN ORDER, contact your Graco distributor or call 1-800-690-2894 to identify the nearest distributor.

*All written and visual data contained in this document reflects the latest product information available at the time of publication.
Graco reserves the right to make changes at any time without notice.*

Original instructions. This manual contains English. MM 3A5577

Graco Headquarters: Minneapolis

International Offices: Belgium, China, Japan, Korea

GRACO INC. AND SUBSIDIARIES • P.O. BOX 1441 • MINNEAPOLIS MN 55440-1441 • USA
Copyright 2018, Graco Inc. All Graco manufacturing locations are registered to ISO 9001.

www.graco.com
Revision F, January 2024

